

ASSEMBLY INSTRUCTION ИНСТРУКЦИЯ ПО СБОРКЕ

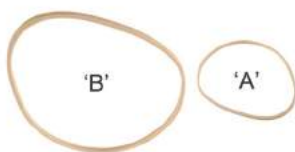

PARKING



EN Rubber bands
PL Gumki recepturki
FR Des élastiques
ES Gomas elásticas
DE Gummibänder
RU Резинки
IT Elastici
CZ Gumičky
CN 枚橡皮筋



EN To tie
PL Wiązać
FR Attacher
ES Para atar
DE Zu binden
RU Завязать
IT Legare
CN 绑
CZ Svázat



EN Remove the burrs with sandpaper
PL Usunąć zadziory papierem ściernym
FR Retirer les bavures avec du papier à polir
ES Quitar las rebabas con el papel esmeril
DE Grate mit Schleifpapier entfernen
RU Удалить заусенцы наждачной бумагой
IT Sbavare con carta vetrata
CZ Vyhladte smirkových papírem
CN 用砂纸去除毛刺。



EN Cut it with a razor blade
PL Odetnij nożem do kopert
FR Couper avec un cutter
ES Cortar con un bisturí
DE Mit Rasierklinge durchschneiden
RU Обрезать канцелярским ножом
IT Tagliare con un coltello da cancelleria
CZ Vyřizněte fezákem
CN 用刀片切断



EN Wax it with a candle
PL Posmaruj za pomocą świecy parafinowej
FR Graisser avec une bougie de paraffine
ES Engrasar con ayuda de una vela de parafina
DE Mit einer Kerze wachsen
RU Смазать парафиновой свечой
IT Lubrificare con candela di paraffina
CZ Navoskujte svíčkou
CN 用干蜡烛上蜡润滑



EN Details should rotate freely
PL Swobodne obracanie
FR Libre rotation
ES Rotación libre
DE Auf freie Rotation achten
RU Свободное вращение
IT Rotazione libera
CZ Části by se měly volně otáčet
CN 流畅地旋转



EN Glue is recommended
PL Zaleca się użycie kleju
FR Recommandé d'utiliser de la colle
ES Recomendado usar pegamento
DE Es wird empfohlen, Kleber zu verwenden
RU Рекомендуется использовать клей
IT Si consiglia di utilizzare la colla
CZ 建议使用胶水
CZ Doporučuje se použít lepidlo



EN Pay attention
PL Uwaga
FR Prêter attention
ES Prestar atención
DE Achtung
RU Уделить внимание
IT Prestare attenzione
CZ Pozor
CN 请注意

EN The manufacturer reserves the right to make changes in the design of the product, not worsening its technical characteristics. Information about the changes made may not be present in this manual.

PL Producent zastrzega sobie prawo do zmiany konstrukcji wyrobu bez pogorszenia jego właściwości technicznych. Niniejsza instrukcja może nie zawierać informacji o zmianach.

FR Le producteur se réserve le droit d'apporter des modifications dans la construction du produit à condition si elles ne portent atteinte à ses caractéristiques techniques. Les renseignements sur les modifications apportées peuvent ne pas être dans la présente notice.

ES El fabricante se reserva el derecho de introducir modificaciones en la construcción del producto, que no empeoran sus características técnicas. Datos sobre modificaciones introducidas pueden no aparecer en esta instrucción.

DE Der Hersteller behält sich das Recht auf Designänderungen, die die technischen Merkmale und Funktionen nicht negativ beeinflussen, vor.

RU Производитель оставляет за собой право вносить изменения в конструкцию изделия, не ухудшающие его технические характеристики. Сведения о внесенных изменениях могут отсутствовать в настоящей инструкции.

IT Il produttore si riserva il diritto di apportare modifiche al design del prodotto, non peggiorando le sue caratteristiche tecniche. Informazioni sulle modifiche apportate potrebbero non essere presenti in questo manuale.

CZ Výrobce si vyhrazuje právo na takové změny v designu produktu, které nebudou mít za následek zhoršení technických vlastností. Informace o změnách nemusí být v návodu uvedeny.

CN 制造商保留对产品设计的权利，一切改良旨在增强产品的技术性能。改良处若未出现在手册中，敬请谅解

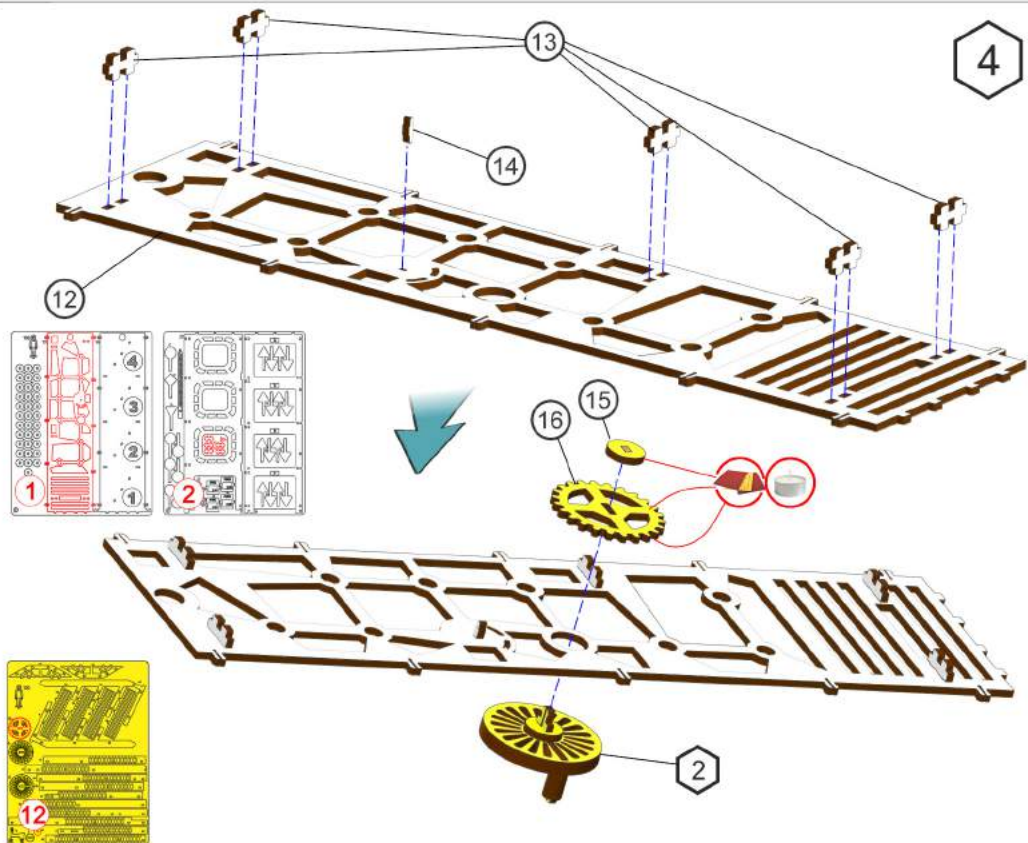
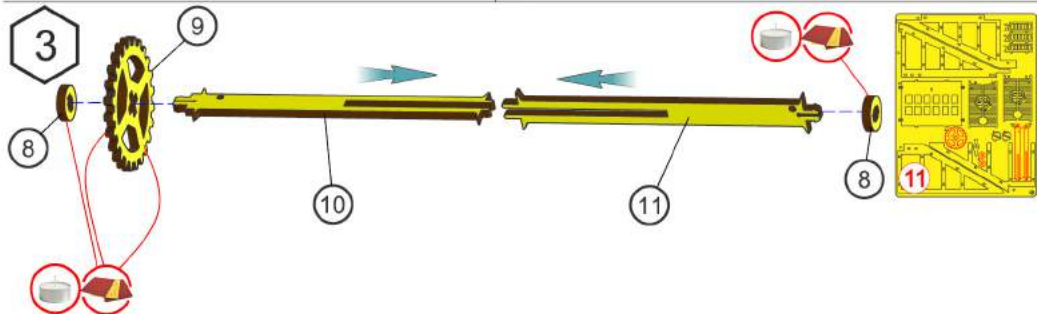
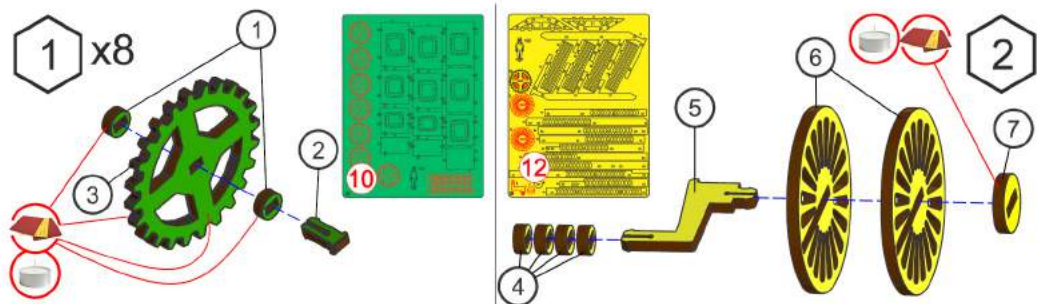

5

3

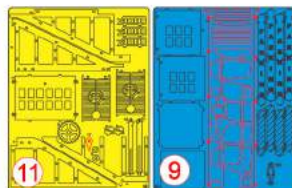

1

17

4

18

'B'



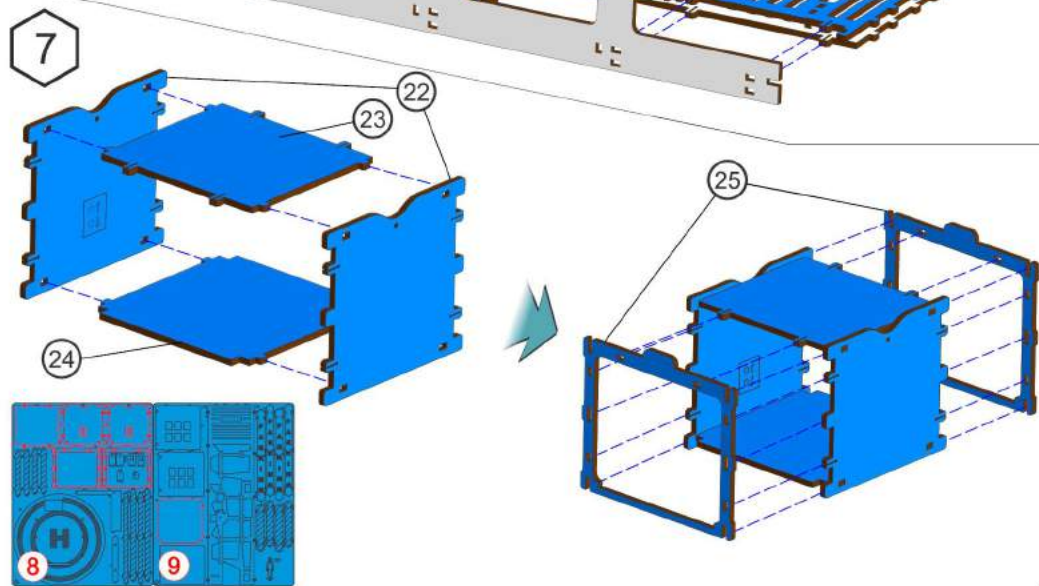
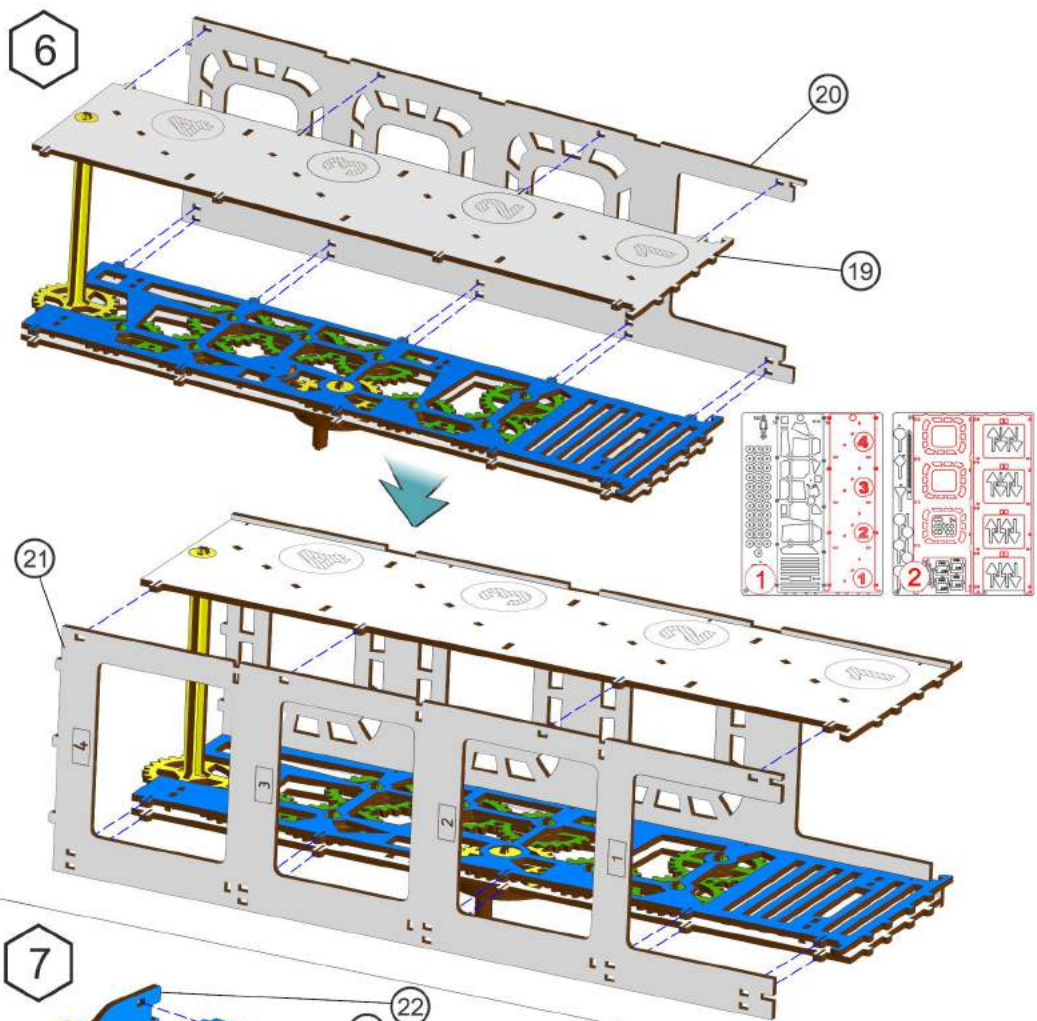

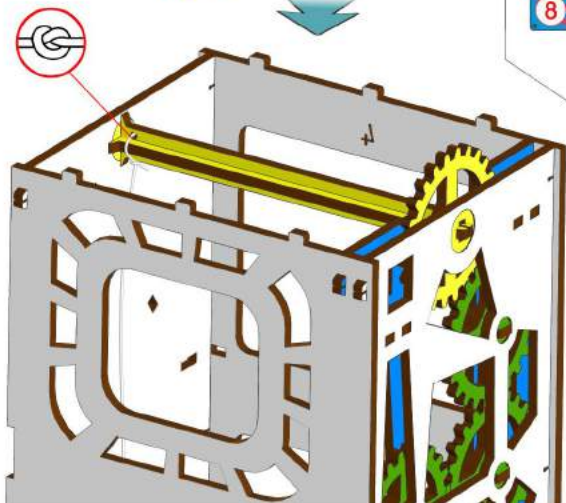
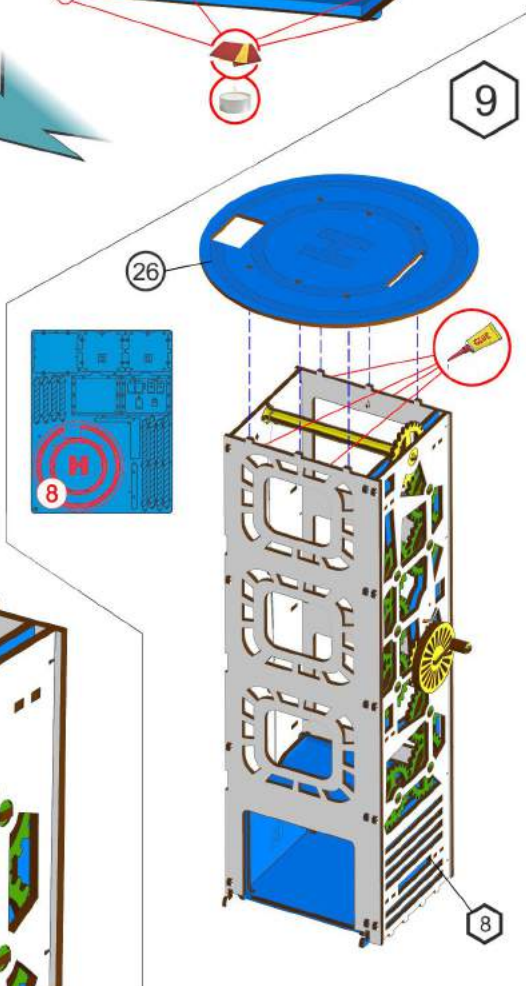
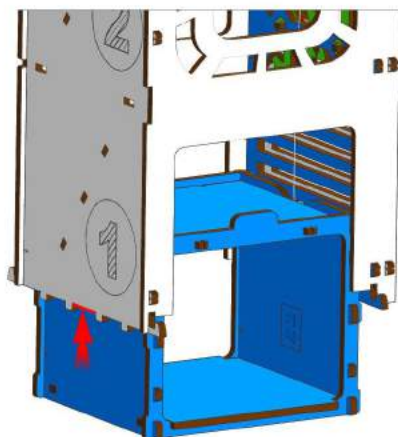
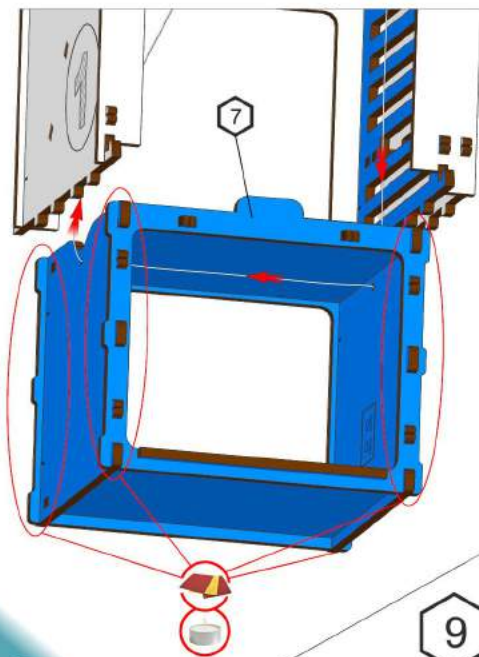
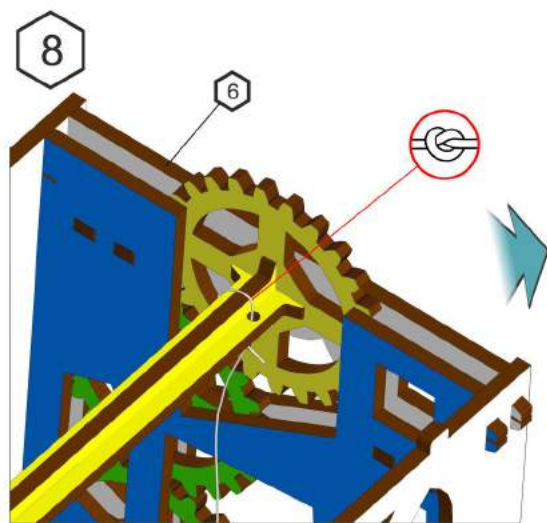

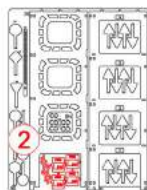
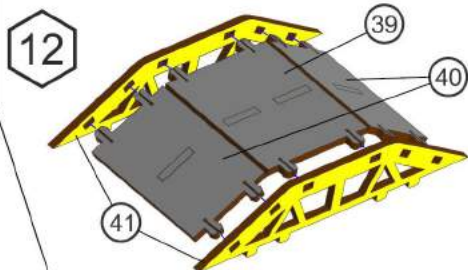
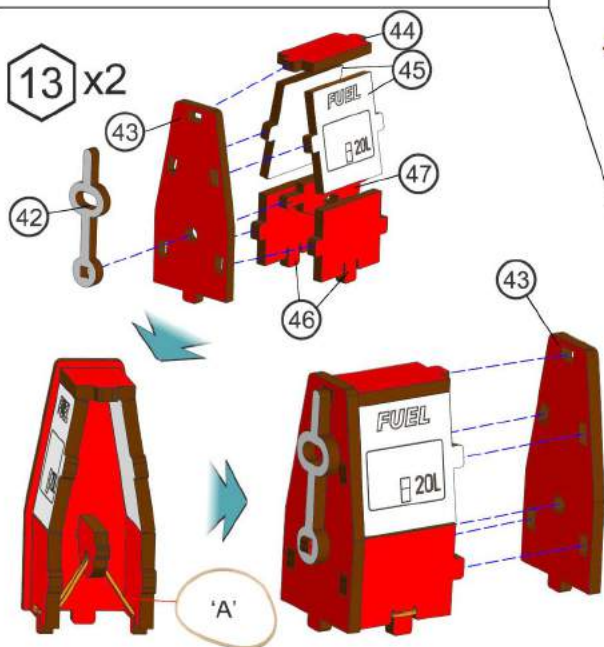
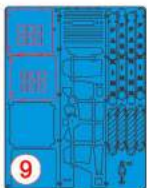
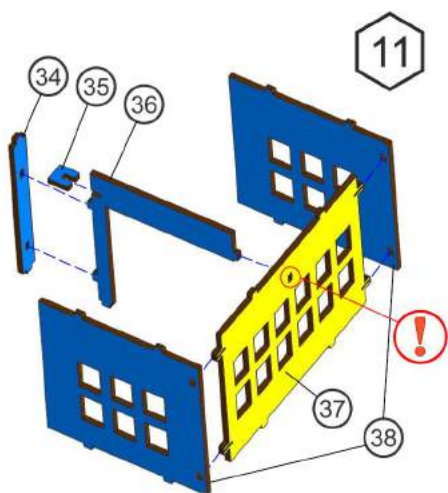
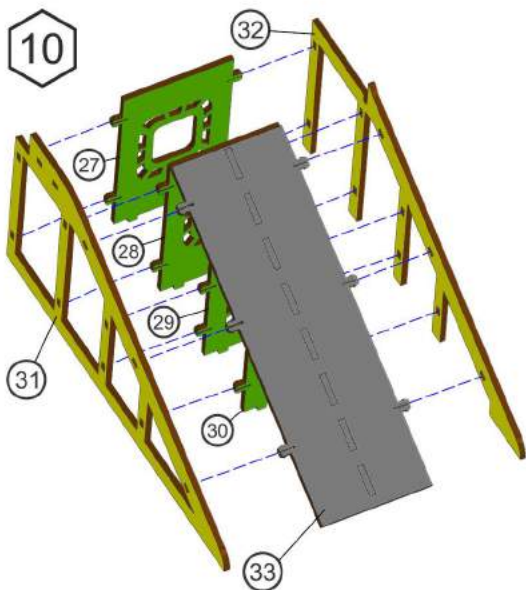

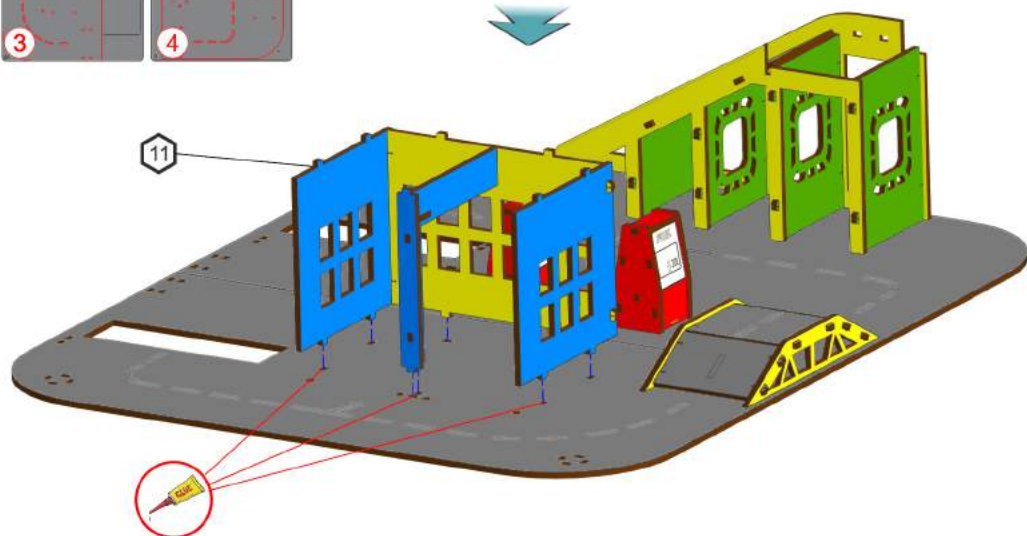
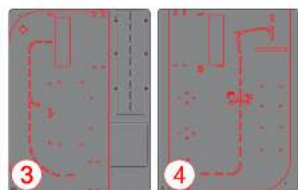
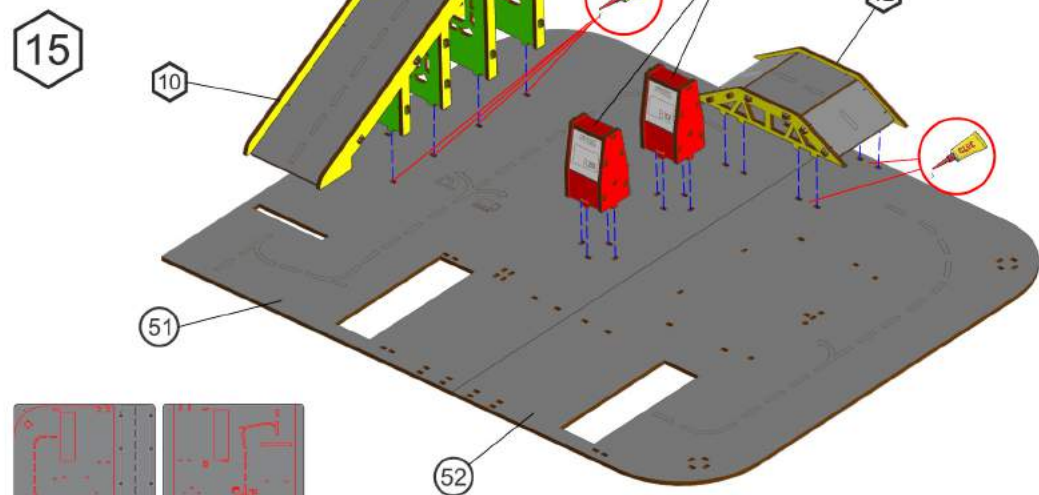
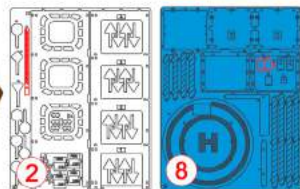
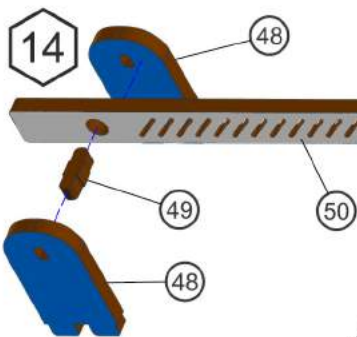

16

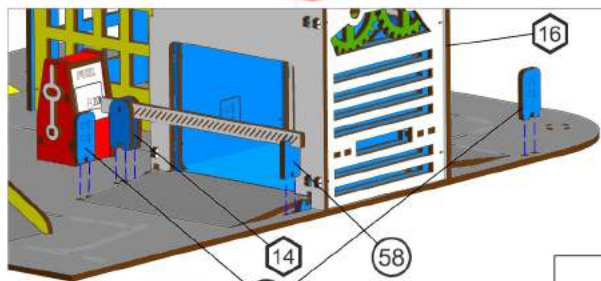
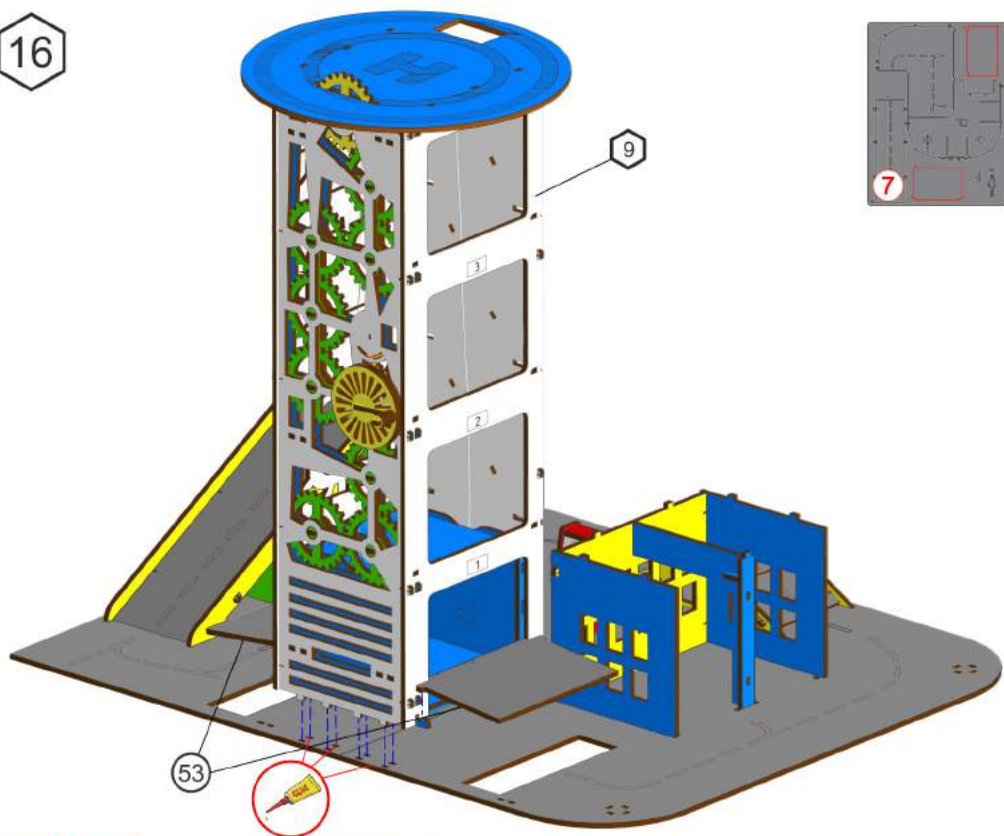

18

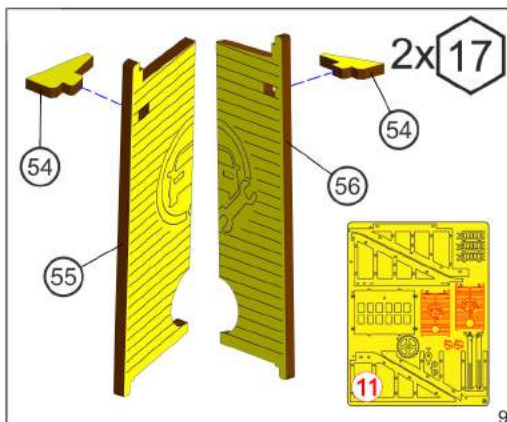
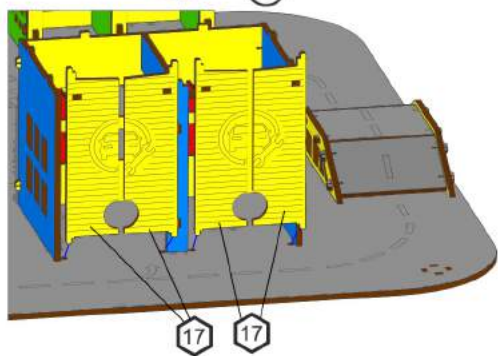

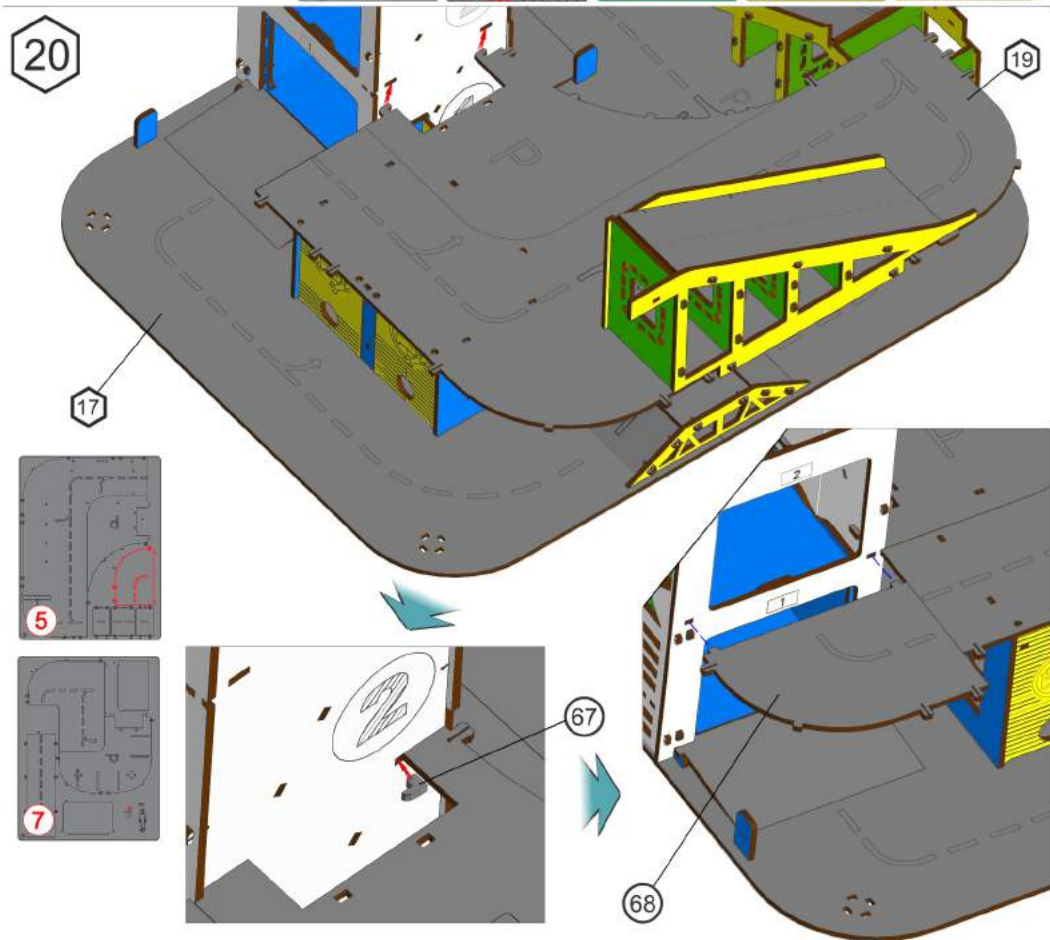
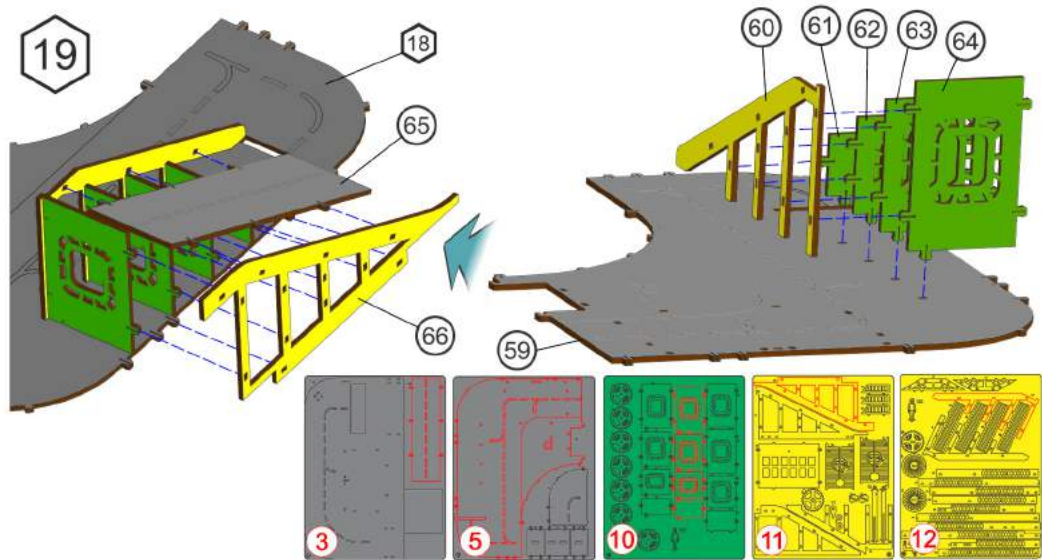

21

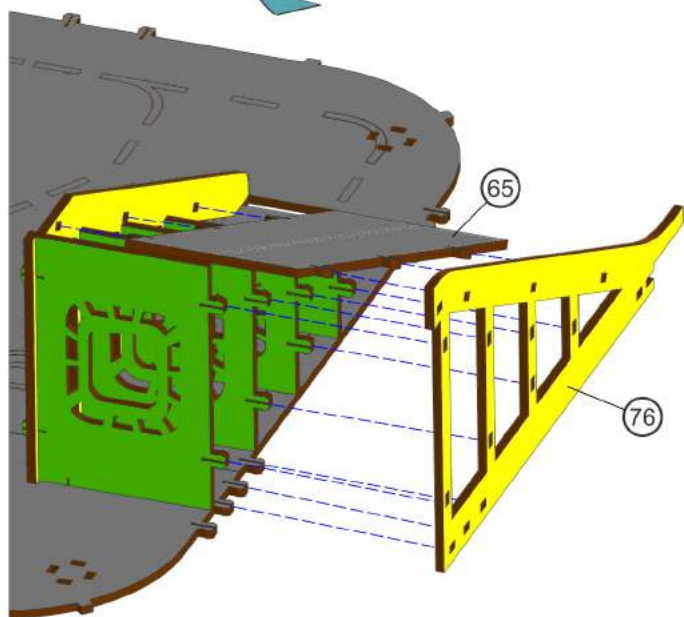
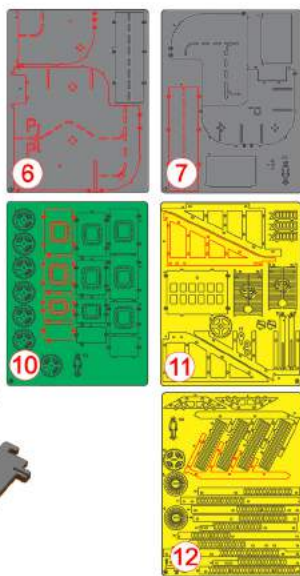
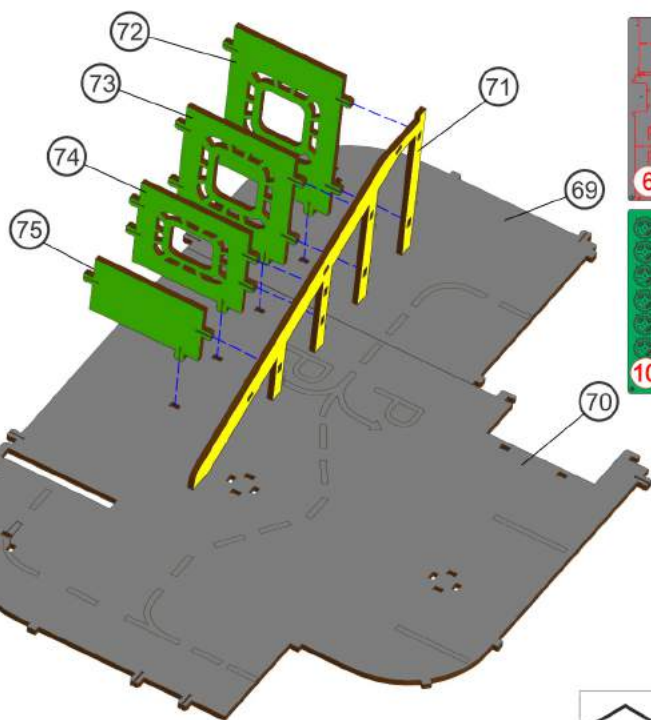

22 x2

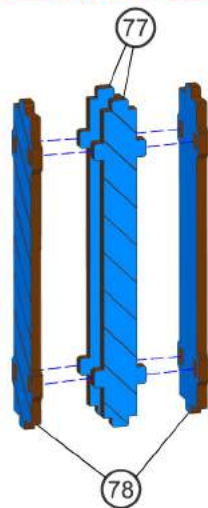
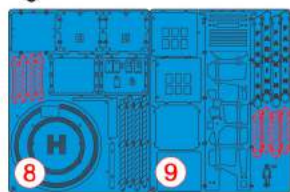

23

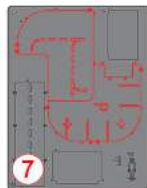
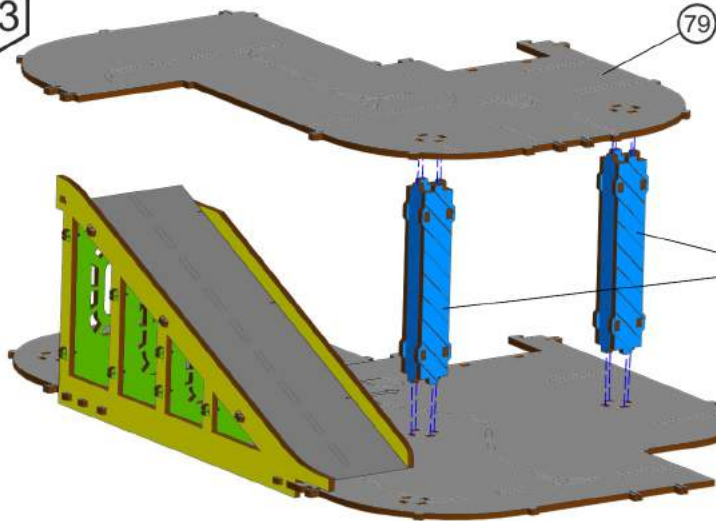

22

21

24x2

80

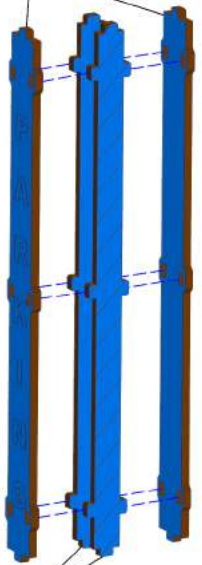

25

20

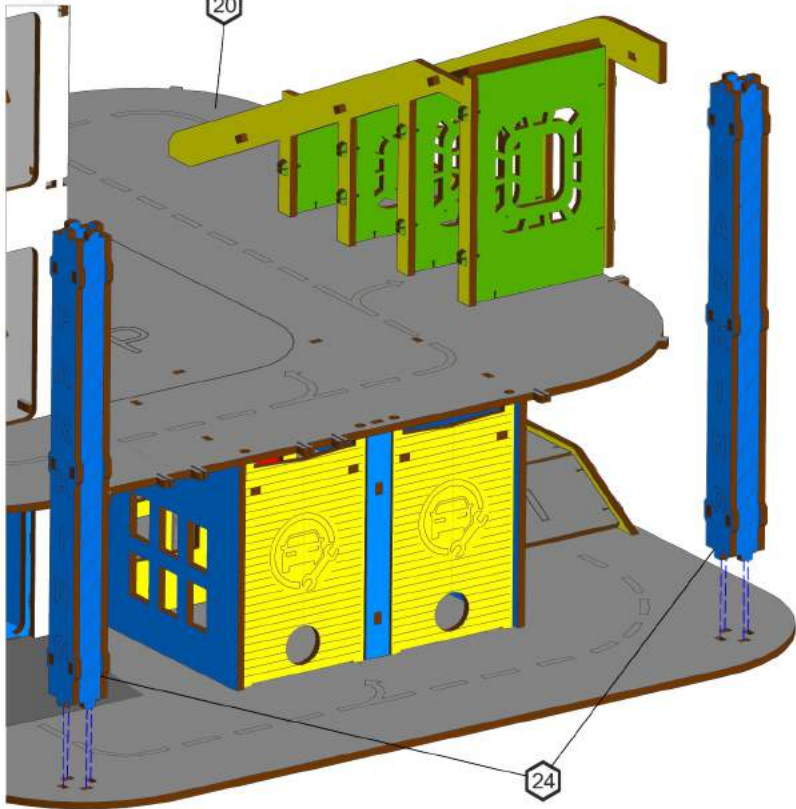

24

81

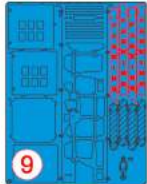
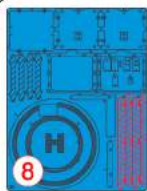

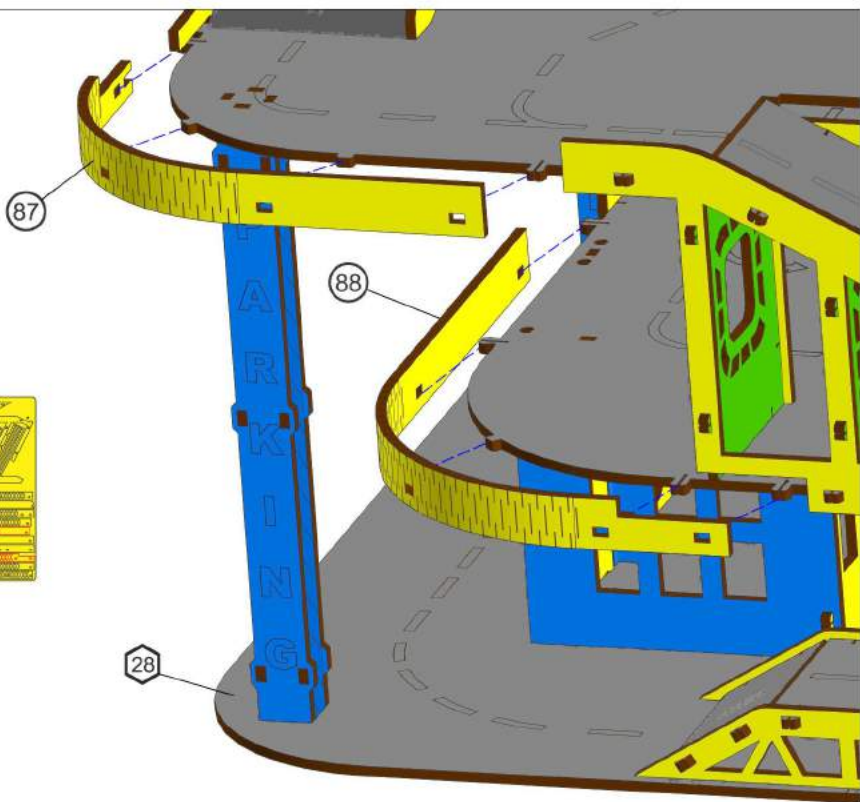
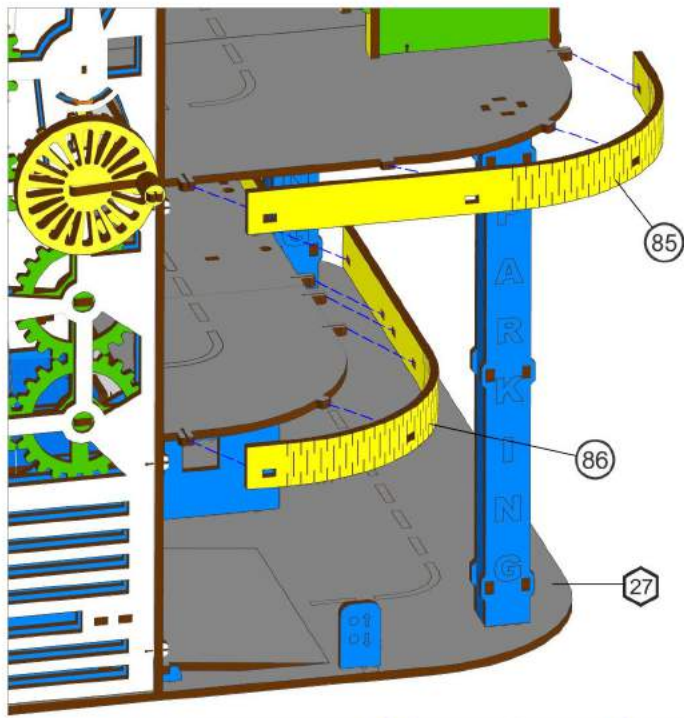

30

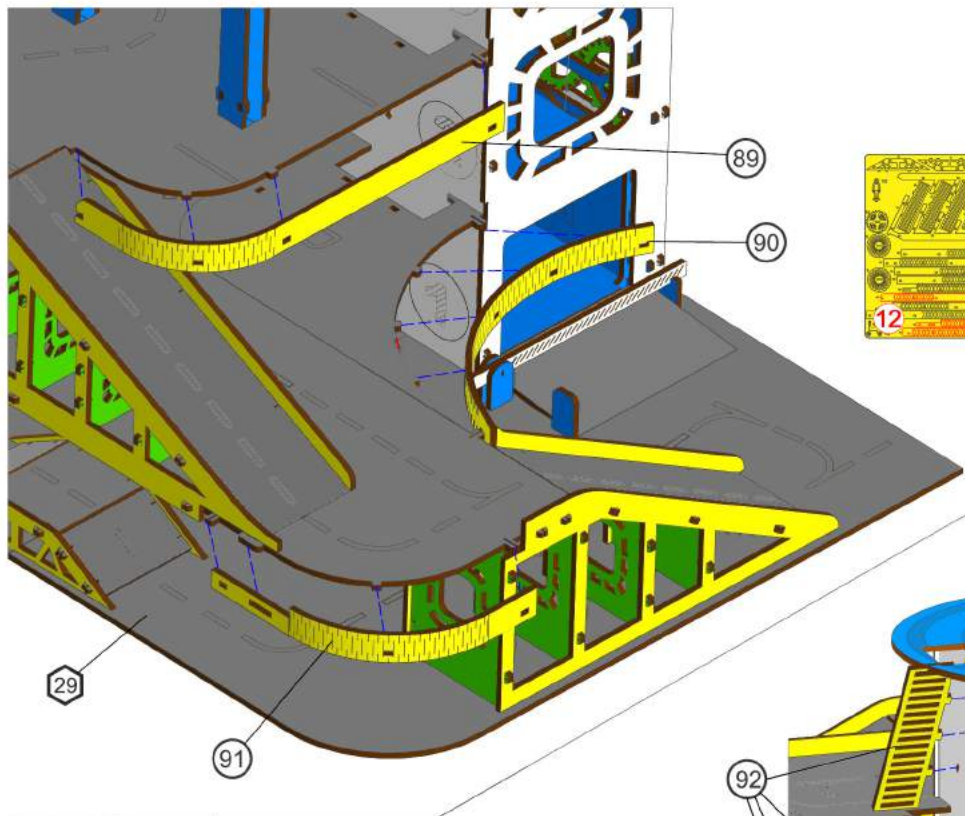

31

